

SELF DRILLING SCREW

SELF DRILLING SCREW FOR FASTENING TO HEAVY STEEL

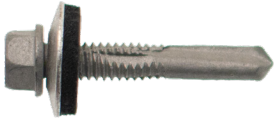

- #5 drill point for one step installation with no need for predrilling
- Tall head for easy and stable mounting
- Surface treated with ZYTEC™ M for good corrosion resistance
- Supplied with washer with bonded EPDM for better load distribution and sealing abilities
- Available in more than 500 colours (QUALICOAT certified powder)



European Technical Assessment ETA-25/0383



Effective length



Hex head



Corrosion category C3



Hardened steel

PRODUCT RANGE

MG/PG	Item no.	Item name	Washer [mm]	Thread [mm]	Length L [mm]	Effective length L _{ef} [mm]	Drill capacity [mm]	Head [mm]	Unit [pcs]
06 2390	12890	HWH 5.5 X 32 #5 "A" HX8 TC	-	Ø5.5	32	12.5	4.0 - 12.5	Ø10.0 HEX 8.0	250
	12877	HWH 5.5 X 32 #5 "A" HX8 TC ALU-16B	ALU Ø16			9.0			250
	10208	HWH 5.5 X 38 #5 "A" HX8 TC	-		38	18.5			250
	12092	HWH 5.5 X 38 #5 "A" HX8 TC ALU-16B	ALU Ø16			15.0			150
	12878	HWH 5.5 X 51 #5 "A" HX8 TC	-		51	31.5			100
	12878	HWH 5.5 X 51 #5 "A" HX8 TC ALU-16B	ALU Ø16			28.0			
	12892	HWH 5.5 X 76 #5 "A" HX8 TC	-		76	56.5			100
	12879	HWH 5.5 X 76 #5 "A" HX8 TC ALU-16B	ALU Ø16			53.0			
	12893	HWH 5.5 X 102 #5 "A" HX8 TC	-		102	82.5			100
	12880	HWH 5.5 X 102 #5 "A" HX8 TC ALU-16B	ALU Ø16			79.0			

TYPICAL APPLICATION

- Fastening of cladding to steel

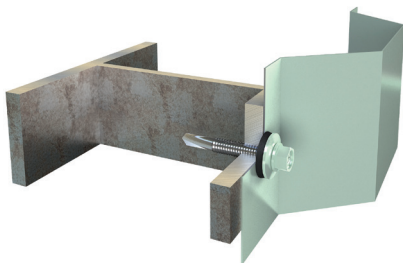

INSTALLATION INSTRUCTIONS

For optimal performance it is important to follow the installation instructions. An incorrect installation may lead to decreased sealing abilities and/or load bearing capacity.

For optimal drill performance, it is recommended that the rotational speed is 1000 - 1600 RPM.

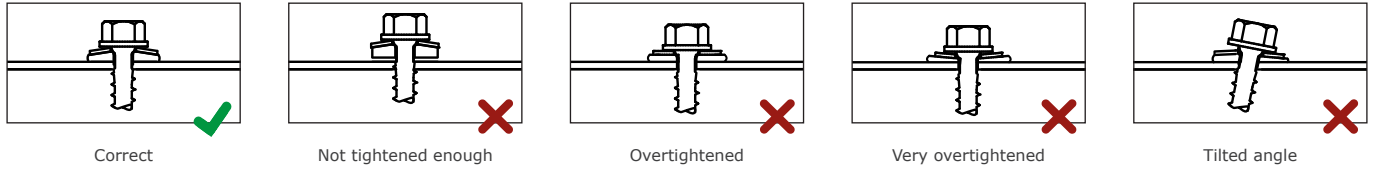

TECHNICAL DATA

Outer diameter, D	[mm]	Ø5.5
Inner diameter, d	[mm]	Ø4.0
Head diameter, d_k	[mm]	Ø10.0
Washer diameter, d_w	[mm]	Ø16.0
Drill point diameter, d_p	[mm]	Ø4.7
Drill point length, l_p	[mm]	15.0
Pitch, P	[mm]	1.8
Drive type, R	[-]	HEX 8.0

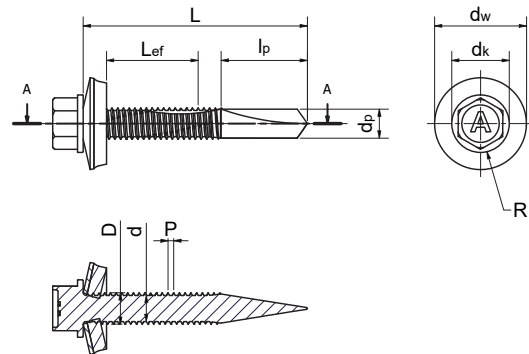

DESIGN RESISTANCE - WITHOUT WASHER

The design resistance of the screw is determined in accordance with european technical assessment ETA-25/0383.

The resistance when loaded in tension, N_{Rd} , appears from the table on the right and is the minimum value of the pull-out resistance of the supporting object, the pull-through resistance of the fixed object, and the tension resistance of the screw.

The resistance when loaded in shear, V_{Rd} , appears from the table on the right and is the minimum value of the bearing resistance of the supporting object and the fixed object, and the shear resistance of the screw.

The theoretical values must be considered indicative since the conditions at the construction site may vary. Practical tests of the specific application are recommended for verification of the listed values.

Assumptions:

Fixed object: Steel S280GD - EN 10346

Supporting object: Steel S280GD - EN 10346

t_I = Thickness of the fixed object [mm]

t_{II} = Thickness of the supporting object [mm]

All resistances are stated in kN (1 kN \approx 100 kg)

Safety factor: $\gamma_M = 1.35$

MG/PG: 06 2390 HWH 5.5 X L #5 "A" HX8 TC ALU-16B

Design resistance when loaded in tension, N_{Rd} [kN]						
$t_I \backslash t_{II}$	4.00	5.00	6.00	8.00	10.00	12.00
0.50	0.61	0.61	0.61	0.61	0.61	0.61
0.55	0.69	0.69	0.69	0.69	0.69	-
0.63	0.81	0.81	0.81	0.81	0.81	-
0.75	1.02	1.02	1.02	1.02	1.02	-
0.88	1.35	1.35	1.35	1.35	1.35	-
1.00	1.67	1.67	1.67	1.67	1.67	-
1.25	1.67	1.67	1.67	1.67	1.67	-
1.50	1.67	1.67	1.67	1.67	1.67	-
1.75	1.67	1.67	1.67	1.67	1.67	-
2.00	1.67	1.67	1.67	1.67	1.67	-

Design resistance when loaded in shear, V_{Rd} [kN]						
$t_I \backslash t_{II}$	4.00	5.00	6.00	8.00	10.00	12.00
0.50	1.67	1.67	1.67	1.67	1.67	1.67
0.55	1.88	1.88	1.88	1.88	1.88	-
0.63	2.20	2.20	2.20	2.20	2.20	-
0.75	2.72	2.72	2.72	2.72	2.72	-
0.88	3.24	3.24	3.24	3.24	3.24	-
1.00	3.76	3.76	3.76	3.76	3.76	-
1.25	4.43	4.43	4.43	4.43	4.43	-
1.50	5.09	5.09	5.09	5.09	5.09	-
1.75	5.09	5.09	5.09	5.09	5.09	-
2.00	5.09	5.09	5.09	5.09	5.09	-

DESIGN RESISTANCE - WITH WASHER

The design resistance of the screw is determined in accordance with european technical assessment ETA-25/0383.

The resistance when loaded in tension, N_{Rd} , appears from the table on the right and is the minimum value of the pull-out resistance of the supporting object, the pull-through resistance of the fixed object, and the tension resistance of the screw.

The resistance when loaded in shear, V_{Rd} , appears from the table on the right and is the minimum value of the bearing resistance of the supporting object and the fixed object, and the shear resistance of the screw.

The theoretical values must be considered indicative since the conditions at the construction site may vary. Practical tests of the specific application are recommended for verification of the listed values.

Assumptions:

Fixed object: Steel S280GD - EN 10346

Supporting object: Steel S280GD - EN 10346

t_I = Thickness of the fixed object [mm]

t_{II} = Thickness of the supporting object [mm]

All resistances are stated in kN (1 kN \approx 100 kg)

Safety factor: $\gamma_M = 1.35$

MG/PG: 06 2390 HWH 5.5 X L #5 "A" HX8 TC ALU-16B

Design resistance when loaded in tension, N_{Rd} [kN]						
$t_I \backslash t_{II}$	4.00	5.00	6.00	8.00	10.00	12.00
0.50	1.31	1.31	1.31	1.31	1.31	1.31
0.55	1.45	1.45	1.45	1.45	1.45	-
0.63	1.74	1.74	1.74	1.74	1.74	-
0.75	2.02	2.02	2.02	2.02	2.02	-
0.88	2.12	2.12	2.12	2.12	2.12	-
1.00	2.21	2.21	2.21	2.21	2.21	-
1.25	2.82	2.82	2.82	2.82	2.82	-
1.50	3.61	3.61	3.61	3.61	3.61	-
1.75	3.61	3.61	3.61	3.61	3.61	-
2.00	3.61	3.61	3.61	3.61	3.61	-

Design resistance when loaded in shear, V_{Rd} [kN]						
$t_I \backslash t_{II}$	4.00	5.00	6.00	8.00	10.00	12.00
0.50	1.67	1.67	1.67	1.67	1.67	1.67
0.55	1.88	1.88	1.88	1.88	1.88	-
0.63	2.20	2.20	2.20	2.20	2.20	-
0.75	2.72	2.72	2.72	2.72	2.72	-
0.88	3.24	3.24	3.24	3.24	3.24	-
1.00	3.76	3.76	3.76	3.76	3.76	-
1.25	4.43	4.43	4.43	4.43	4.43	-
1.50	5.09	5.09	5.09	5.09	5.09	-
1.75	5.09	5.09	5.09	5.09	5.09	-
2.00	5.09	5.09	5.09	5.09	5.09	-

DECLARATION OF PERFORMANCE

In compliance with 'REGULATION (EU) No 305/2011 of the European Parliament and of the Council of 9 March 2011 laying down harmonised conditions for the marketing of construction products' (the Construction Products Regulation or CPR), it is stated that the performance of the construction product identified below is in conformity with the declared performance.

Product identification

MG:06 PG:2390 | HWH 5.5 X L #5 "A" HX8 TC ALU-16B

(Main Group # Product Group # | Item name)

The screws mentioned above are packed in branded cartons clearly marked with CE according to ETA-25/0383. For specification of the intended use and declared performance of the product please refer to the technical data sheet.

Placed on the market by:

ASTON SWEDEN AB

Hangarvägen 23

SE-691 35 Karlskoga, Sweden

(Name / address)

European Assessment Document: EAD 330046-01-0602

European Technical Assessment: ETA-25/0383

Technical Assessment Body: ETA Danmark

Notified Body no.: 1488

System of AVCP: 2+

This declaration of performance is issued under the sole responsibility of the manufacturer identified above.



Morten Johansen
M.Sc., Engineering



SWEDEN

Company stamp
RED HORSE | dissing as

2018-04-23

Date of issue